

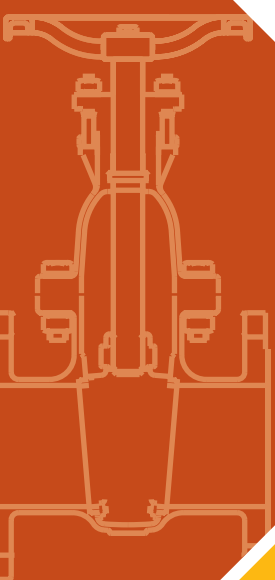

**fivalco**®



# 2024 **PRODUCT CATALOGUE**

**STAINLESS STEEL  
INDUSTRIAL VALVES**

A truly world class manufacturer serving Global Markets





## A True Manufacturer

Fivalco is an inventor and leading manufacturer of superior flow control products. Our products are designed-tested and certified by the leading testing agencies, including the Underwriters Laboratories (UL), Factory Mutual (FM), Water Regulations Approval Scheme (WRAS), National Sanitation Foundation (NSF) and etc, based on a wide range of global standards.

Founded in 1985 by Sir Michael J.Graham in California, USA, we have dedicated ourselves to the production of critical flow control products, serving the critical Fire Protection, Heating, Ventilation & Air Conditioning (HVAC), General Process Industries, Water Supply & Water Treatment markets worldwide.

We operate from our main facilities utilising the latest manufacturing technologies and equipment available to produce world class flow control products. We strive to continue to provide the highest quality products to discerning customers at all times.

# List

F1116-50 / F1116-51	STAINLESS STEEL WAFER BUTTERFLY VALVE PN16	1
F1216-50 / F1216-51	STAINLESS STEEL FULL LUG BUTTERFLY VALVE PN16	3
F13C16-50 / F13C16-51	STAINLESS STEEL DOUBLE FLANGE BUTTERFLY VALVE PN16	5
F23M16-50 / F23M16-51 F23M25-50 / F23M25-51	STAINLESS STEEL NRS METAL SEAT GATE VALVE PN16 STAINLESS STEEL NRS METAL SEAT GATE VALVE PN25	7
F23MR16-50 / F23MR16-51	STAINLESS STEEL OS&Y METAL SEAT GATE VALVE PN16	9
F33S16-50 / F33S16-51	STAINLESS STEEL OS&Y S-PATTERN GLOBE VALVE PN16	10
F43D16-50 / F43D16-51	STAINLESS STEEL 2-PIECE BODY BALL VALVE PN16	11
F43T16-50 / F43T16-51	STAINLESS STEEL 3-PIECE BODY BALL VALVE PN16	12
F51DD16-50 / F51DD16-51 F51DD25-50 / F51DD25-51	STAINLESS STEEL WAFER DOUBLE DOOR CHECK VALVE PN16 STAINLESS STEEL WAFER DOUBLE DOOR CHECK VALVE PN25	13
F53S16-50 / F53S16-51	STAINLESS STEEL SWING CHECK VALVE PN16	14
F73Y16-50 / F73Y16-51	STAINLESS STEEL Y-TYPE STRAINER PN16	15
F2S200-50 / F2S200-51	STAINLESS STEEL NRS GATE VALVE 200PSI	16
F3S200R-50 / F3S200R-51	STAINLESS STEEL RISING STEM GLOBE VALVE 200PSI	17
F4S640-50 / F4S640-51	STAINLESS STEEL 1-PIECE BODY BALL VALVE 1000PSI	18
F4S64D-50 / F4S64D-51	STAINLESS STEEL 2-PIECE BODY BALL VALVE 1000PSI	19
F4S64T-50 / F4S64T-51	STAINLESS STEEL 3-PIECE BODY BALL VALVE 1000PSI	20
F4S64TB-50 / F4S64TB-51	STAINLESS STEEL 3-PIECE BODY BALL VALVE BUTT WELD 1000PSI	21
F5S200S-50 / F5S200S-51	STAINLESS STEEL SWING CHECK VALVE 200PSI	22
F5S63L-50 / F5S63L-51	STAINLESS STEEL LIFT CHECK VALVE 1000PSI	23
F7S800-50 / F7S800-51	STAINLESS STEEL Y-TYPE STRAINER 800PSI	24
F83MJ16-50 / F83MJ16-51 F83MJ25-50 / F83MJ25-51	STAINLESS STEEL EXPANSION JOINT PN16 STAINLESS STEEL EXPANSION JOINT PN25	25
F83MH16-50 / F83MH16-51 F83MH16-50 / F83MH25-51	STAINLESS STEEL FLEXIBLE HOSE PN16 STAINLESS STEEL FLEXIBLE HOSE PN25	26
F85MH16 F85MH25	STAINLESS STEEL FLEXIBLE HOSE PN16 STAINLESS STEEL FLEXIBLE HOSE PN25	27



**An American brand trusted for over 35 years**

The quality goes in before our name goes on 



SS304 PN16 F1216-50 | SS316 PN16 F1216-51

# STAINLESS STEEL FULL LUG BUTTERFLY VALVE

# STAINLESS STEEL WAFER BUTTERFLY VALVE

SS304 PN16 F1116-50  
SS316 PN16 F1116-51



## FEATURES & SPECIFICATIONS

- Higher strength for disc with pinned single shaft ensure optimal alignment
- Centrally mounted disc and hydrodynamic design minimize pressure loss
- Can be installed at horizontal or vertical pipe line
- Phenolic backed rubber seat is non-collapsible, stretch resistant and easily replaceable
- Excellent flow characteristic with flow in either direction
- Design conforms to BS EN 593 / BS 5155 / MSS SP-67 / API 609
- Precision machining of disc for low operating torque



## TECHNICAL SPECIFICATIONS

Size	DN50 ... DN600
Body Design	Wafer
Working Pressure	16bar
Shell Test Pressure (x1.5)	24bar
Seat Test Pressure (x1.1)	17.6bar
Working Temperature	-10°C ... 120°C
Applicable Medium	Water, Oil, Gas
Operator	Lever, Wormgear, Electric Actuator
Connection	BS 4504 PN10 / PN16 EN1092-2 PN10 / PN16 JIS B2239 10K / 16K ANSI B16.1 Class 125 / 150
Optional Accessories	Chain Wheel, Limit Switch

## MATERIAL SPECIFICATIONS

Part	Material
Body	Stainless Steel 304 Stainless Steel 316
Disc	Stainless Steel 304 Stainless Steel 316
Seat	EPDM
Stem	Stainless Steel 431
Packing	PTFE
Bush	Polymer

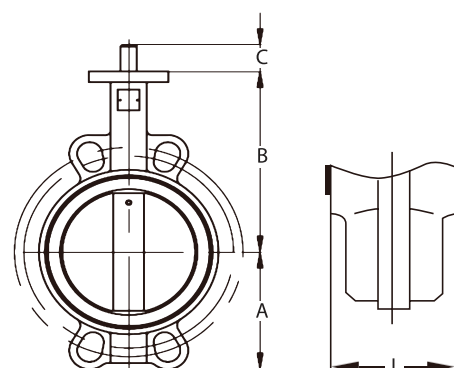

## DIMENSIONS

DN	(mm)	50	65	80	100	125	150	200	250	300	350	400	450	500	600
	(inch)	2	2½	3	4	5	6	8	10	12	14	16	18	20	24
A		82	90	97	110	120	147	168	200	220	258	280	310	345	400
B		126	132	143	155	160	185	223	263	300	335	370	390	430	490
C		25	25	25	25	25	25	35	40	40	40	55	55	55	70
L		42	44	44	51	54	54	59	65	76	77	87	108	128	152

## VALVE COEFFICIENT (FULL OPEN)

DN (mm)	50	65	80	100	125	150	200	250	300	350	400	450	500	550	600
DN (inch)	2	2½	3	4	5	6	8	10	12	14	16	18	20	22	24
<b>Cv</b>	135	220	302	600	1022	1579	3136	5340	8250	11917	16388	21705	27908	35170	43116

$C_v = 1.17K_v$

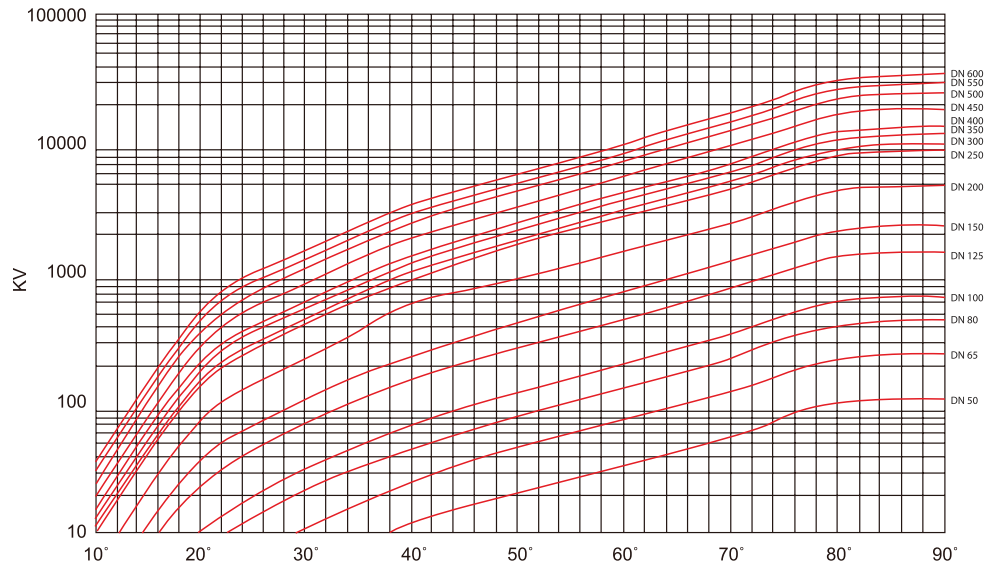

## DIMENSIONS - VALVE OPERATOR

Malleable Iron / Stainless Steel Lever  
Stainless Steel SUS304 Top Indicator Plate

(mm)

DN (mm)	50-80	100-125	150	200
DN (inch)	2-3	4-5	6	8
A	195	266	328	386
B	95	109	109	164

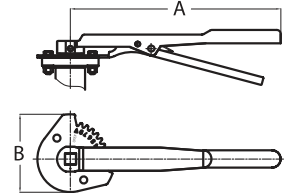

Cast Iron 1-Stage Worm Gear and Handwheel  
Carbon Steel Gear Box Shaft

VALVE DIAMETER	D1	∅	H	H1	L1	L2	L3
DN50 - DN80	65	150	33	70	216	45	127
DN100 - DN150	90	150	33	70	216	45	127
DN200 - DN250	125	285	36	76	303	63.5	170
DN300 - DN350	125	285	40	79	300	80	190
DN400	175	385	79	232.5	300	80	190
DN450 - DN550	175	390	108	251	397/427	120	279

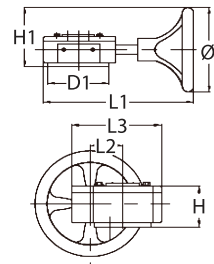

Cast Iron 2-Stage Worm Gear and Handwheel  
Carbon Steel Gear Box Shaft

VALVE DIAMETER	D1	∅	H	H1	L1	L2	L3	L4	L5
DN600	210	285	125	271	107	100	156	168	107

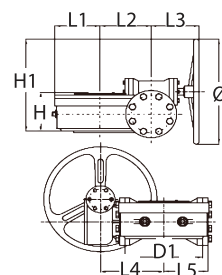

# STAINLESS STEEL FULL LUG BUTTERFLY VALVE

SS304 PN16 F1216-50  
SS316 PN16 F1216-51



## FEATURES & SPECIFICATIONS

- Higher strength for disc with pinned single shaft ensure optimal alignment
- Centrally mounted disc and hydrodynamic design minimize pressure loss
- Can be installed at horizontal or vertical pipe line
- Phenolic backed rubber seat is non-collapsible, stretch resistant and easily replaceable
- Excellent flow characteristic with flow in either direction
- Design conforms to BS EN 593 / BS 5155 / MSS SP-67 / API 609
- Precision machining of disc for low operating torque



## TECHNICAL SPECIFICATIONS

Size	DN50 ... DN600
Body Design	Lugged
Working Pressure	16bar
Shell Test Pressure (x1.5)	24bar
Seat Test Pressure (x1.1)	17.6bar
Working Temperature	-10°C ... 120°C
Applicable Medium	Water, Oil, Gas
Operator	Lever, Wormgear, Electric Actuator
Connection	BS 4505 PN10 / PN16 EN1092-2 PN10 / PN16 JIS B2239 10K / 16K ANSI B16.1 Class 125 / 150
Optional Accessories	Chain Wheel, Limit Switch

## MATERIAL SPECIFICATIONS

Part	Material
Body	Stainless Steel 304 Stainless Steel 316
Disc	Stainless Steel 304 Stainless Steel 316
Seat	EPDM
Stem	Stainless Steel 431
Packing	PTFE
Bush	Polymer

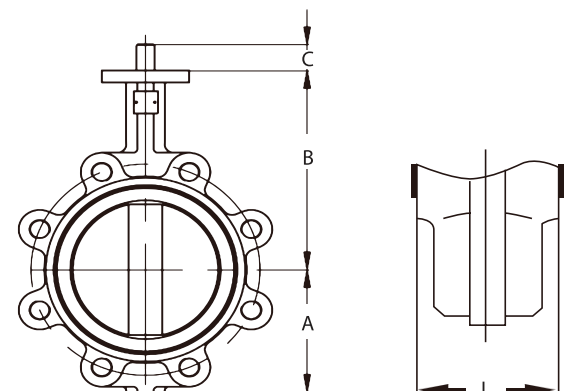

## DIMENSIONS

DN	(mm) (inch)	(mm)													
		50	65	80	100	125	150	200	250	300	350	400	450	500	600
		2	2½	3	4	5	6	8	10	12	14	16	18	20	24
	A	82	90	97	110	120	147	168	200	220	258	280	310	345	400
	B	126	132	143	155	160	185	223	263	300	335	370	390	430	490
	C	25	25	25	25	25	25	35	40	40	40	55	55	55	70
	L	42	44	44	51	54	54	59	65	76	77	87	108	128	152

## VALVE COEFFICIENT (FULL OPEN)

DN (mm)	50	65	80	100	125	150	200	250	300	350	400	450	500	550	600
DN (inch)	2	2½	3	4	5	6	8	10	12	14	16	18	20	22	24
Cv	135	220	302	600	1022	1579	3136	5340	8250	11917	16388	21705	27908	35170	43116
Cv = 1.17Kv															

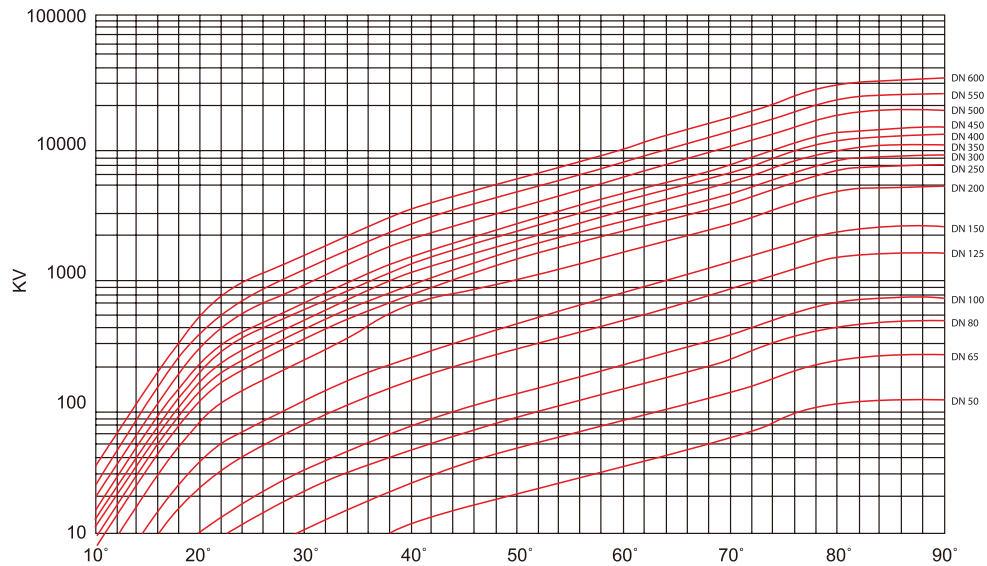

## DIMENSIONS - VALVE OPERATOR

Malleable Iron / Stainless Steel Lever  
Stainless Steel SUS304 Top Indicator Plate

(mm)

DN (mm)	50-80	100-125	150	200
DN (inch)	2-3	4-5	6	8
A	195	266	328	386
B	95	109	109	164

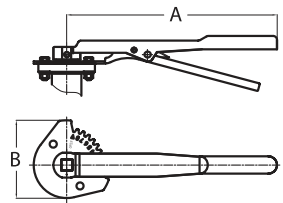

Cast Iron 1-Stage Worm Gear and Handwheel  
Carbon Steel Gear Box Shaft

VALVE DIAMETER	D1	∅	H	H1	L1	L2	L3
DN50 - DN80	65	150	33	70	216	45	127
DN100 - DN150	90	150	33	70	216	45	127
DN200 - DN250	125	285	36	76	303	63.5	170
DN300 - DN350	125	285	40	79	300	80	190
DN400	175	385	79	232.5	300	80	190
DN450 - DN550	175	390	108	251	397/427	120	279

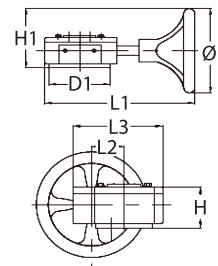

Cast Iron 2-Stage Worm Gear and Handwheel  
Carbon Steel Gear Box Shaft

VALVE DIAMETER	D1	∅	H	H1	L1	L2	L3	L4	L5
DN600	210	285	125	271	107	100	156	168	107

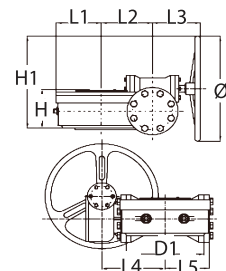

# STAINLESS STEEL DOUBLE FLANGE BUTTERFLY VALVE



SS304 PN16 F13C16-50  
 SS316 PN16 F13C16-51

## FEATURES & SPECIFICATIONS

- Concentric double flange
- Comply with BS EN593 / BS 5155 (Double flange short body) / ISO 5752 / EN 558-1 Basic Series 13 ( Double flange short body)
- Higher strength for disc with pinned single shaft ensure optimal alignment
- Can be installed at horizontal or vertical pipe line
- Flange drilled to EN1092-2 PN16 / ANSI Class 150 / JIS10K / AS 2129 Table E (Specify on order)



## PRESSURE & TEMPERATURE RATINGS

Working Pressure	16bar
Shell Test Pressure (x1.5)	24bar
Seat Test Pressure (x1.1)	17.6 bar
Working Temperature	-20°C ... 110°C
Suitable Media	Water, Oil & Gas

## MATERIAL SPECIFICATIONS

Part	Material
Body	Stainless Steel 304
	Stainless Steel 316
Disc	Stainless Steel 304
	Stainless Steel 316
Stem	Stainless Steel 410
Seat Ring	EPDM
O-Ring	EPDM

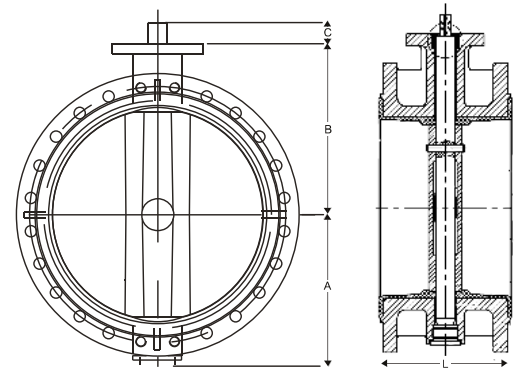

## DIMENSIONS

DN	(mm) (inch)	(mm)													
		50	65	80	100	125	150	200	250	300	350	400	450	500	600
		2	2½	3	4	5	6	8	10	12	14	16	18	20	24
A		80	90	88	108	123	140	178	198	230	260	290	330	290	435
B		130	140	157	165	180	200	212	280	310	325	370	392	431	505
C		25	25	25	28	28	28	35	40	40	40	50	55	65	70
L		108	112	114	127	140	140	152	165	178	190	216	222	229	267

## DIMENSIONS - VALVE OPERATOR

**Malleable Iron / Stainless Steel Lever**  
**Stainless Steel SUS304 Top Indicator Plate**

(mm)

DN	(mm) (inch)	50-80 2-3	100-125 4-5	150 6	200 8
A		195	266	328	386
B		95	109	109	164

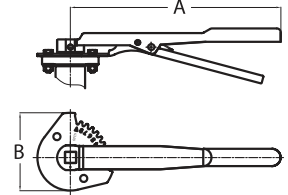

**Cast Iron 1-Stage Worm Gear and Handwheel**  
**Carbon Steel Gear Box Shaft**

VALVE DIAMETER	D1	∅	H	H1	L1	L2	L3
DN50 - DN150	108	145	65	113	212	45	129
DN200 - DN250	146	285	70	182	305	62	171
DN300 - DN350	165	285	77	182	300	85	198
DN400 - DN450	234	385	103	247	423	120	280
DN500 - DN600	276	385	143	270	490	122	316

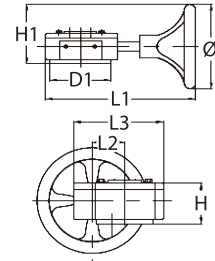

## INSTALLATION & OPERATION GUIDE

1. Ensure sufficient space for valves for easy installation, operation, maintenance and replacement.
2. Verify the valves are suitable for the operating condition such as medium, operating pressure / temperature, etc.
3. Check the I.D. of the flange and pipe to ensure free disc movement.
4. Valves shall be mounted on flanges only after the counter flanges have been welded to pipe and cooled down to the atmospheric temperature. Welding heat may damage the rubber seat of the valves. Never weld the flanges with valves installed. No gasket is required for installation of rubber seated butterfly valves.
5. Position the valves carefully between flanges. Accurate centering between flanges is essential to prevent any damages and problems during operation.
6. Valves should be installed by placing bolts through the hole and tightening carefully, ensuring even contact between the flange and seat. Too tight or space may cause damages to the seat and should be avoided.
7. Cross tighten all the bolts diagonally to distribute the loads evenly over the valves.
8. Turning the valves to ensure sufficient disc clearance.
9. Valves equipped with manual operators must be operated manually. Excessive external force on the operation of valve may damage the valve and / or operator.
10. Blind flange with short pipe should be used for dead end installation.

# STAINLESS STEEL NRS METAL SEAT GATE VALVE

SS304 PN16 / PN25 F23M16-50 / F23M25-50  
 SS316 PN16 / PN25 F23M16-51 / F23M25-51

## FEATURES & SPECIFICATIONS

- Non-rising stem
- Inside screw
- Bolted bonnet
- Metal seat design
- Face to face dimension to DIN 3352 F5
- Flange drilled to BS 4504 PN16 / EN 1092-2 PN16 / BS 4504 PN25 / EN1092-2 PN25 / ANSI Class 150 (Specify on order)
- Applicable for Building Services, Air-Conditioning, Fire Protection, Cold Water Plumbing, Hot Water System, Water Supply Works, Water Treatment Plant, General Industries.



## PRESSURE & TEMPERATURE RATINGS

Working Pressure	16bar	25bar
Shell Test Pressure (x1.5)	24bar	37.5bar
Seat Test Pressure (x1.1)	17.6bar	27.5bar
Working Temperature	-20°C ... 150°C	
Suitable Media	Water	

## MATERIAL SPECIFICATIONS

Part	Material	Specification
Body	Stainless Steel 304	EN 10088-3 1.4301
	Stainless Steel 316	EN 10088-3 1.4401
Disc	Stainless Steel 304	EN 10088-3 1.4301
	Stainless Steel 316	EN 10088-3 1.4401
Stem	Stainless Steel 304	EN 10088-3 1.4301
	Stainless Steel 316	EN 10088-3 1.4401
Cover	Stainless Steel 304	EN 10088-3 1.4301
	Stainless Steel 316	EN 10088-3 1.4401
Packing	PTFE	
Gland	Stainless Steel 304	EN 10088-3 1.4301
Nut	Stainless Steel 304	EN 10088-3 1.4301
Handwheel	Ductile Iron	

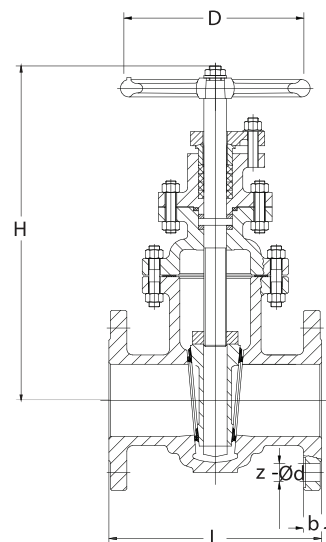

## DIMENSIONS

DN (mm)		50	65	80	100	125	150	200	250
DN (inch)		2	2½	3	4	5	6	8	10
L		250	270	280	300	325	350	400	450
H		400	460	480	550	680	700	800	950
D		215	215	270	270	310	310	340	395
Z-Ød	PN16	4-Ø18	8-Ø18	8-Ø18	8-Ø18	8-Ø18	8-Ø22	12-Ø22	12-Ø26
	PN25	4-Ø18	8-Ø18	8-Ø18	8-Ø22	8-Ø26	8-Ø26	12Ø-Ø26	12-Ø30
b	PN16	18	18	20	20	22	22	24	26
	PN25	20	22	24	24	26	28	30	32

## FEATURES & SPECIFICATIONS

- Rising stem, Outside Screw & Yoke (OS&Y)
- Bolted bonnet
- Metal seat design
- Face to face dimension to DIN 3352 F5
- Flange drilled to BS 4504 PN16 / EN 1092-2 PN16 / ANSI Class 150 (Specify on order)
- Applicable for Building Services, Air-Conditioning, Fire Protection, Cold Water Plumbing, Hot Water System, Water Supply Works, Water Treatment Plant, General Industries.



## PRESSURE & TEMPERATURE RATINGS

Working Pressure	16bar
Shell Test Pressure (x1.5)	24bar
Seat Test Pressure (x1.1)	17.6bar
Working Temperature	-30°C ... 165°C
Suitable Media	Water, Oil & Gas

## MATERIAL SPECIFICATIONS

Part	Material	Specification
Body	Stainless Steel 304	EN 10088-3 1.4301
	Stainless Steel 316	EN 10088-3 1.4401
Disc	Stainless Steel 304	EN 10088-3 1.4301
	Stainless Steel 316	EN 10088-3 1.4401
Stem	Stainless Steel 304	EN 10088-3 1.4301
	Stainless Steel 316	EN 10088-3 1.4401
Packing Cover	Stainless Steel 304	EN 10088-3 1.4301
	Stainless Steel 316	EN 10088-3 1.4401
Gasket	Stainless Steel	
Nut	Stainless Steel	
Handwheel	Ductile Iron	
Packing	PTFE	

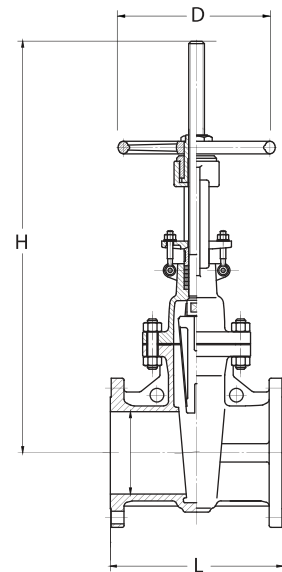

## DIMENSIONS

DN (mm)	15	20	25	32	40	50	65	80	100	125	150	200	250	300
DN (inch)	½	¾	1	1¼	1½	2	2½	3	4	5	6	8	10	12
L	130	150	160	180	200	250	265	280	300	325	350	400	450	500
H	195	205	240	240	370	390	450	490	560	656	845	1041	1244	1474
D	200	200	220	220	240	240	240	240	280	320	360	400	450	560

# STAINLESS STEEL OS&Y METAL SEAT GATE VALVE

SS304 PN25 F23MR25-50  
 SS316 PN25 F23MR25-51



## FEATURES & SPECIFICATIONS

- Rising stem, Outside Screw & Yoke (OS&Y)
- Bolted bonnet
- Metal seat design
- Flange drilled to BS 4504 PN25 / EN1092-2 PN25 / ANSI Class 150 (Specify on order)
- Applicable for Building Services, Air-Conditioning, Fire Protection, Cold Water Plumbing, Hot Water System, Water Supply Works, Water Treatment Plant, General Industries.



## PRESSURE & TEMPERATURE RATINGS

Working Pressure	25bar
Shell Test Pressure (x1.5)	37.5bar
Seat Test Pressure (x1.1)	27.5bar
Working Temperature	-29°C ... 425°C
Suitable Media	Water, Oil & Gas

## MATERIAL SPECIFICATIONS

Part	Material	Specification
Body	Stainless Steel 304	EN 10088-3 1.4301
	Stainless Steel 316	EN 10088-3 1.4401
Disc	Stainless Steel 304	EN 10088-3 1.4301
	Stainless Steel 316	EN 10088-3 1.4401
Stem	Stainless Steel 304	EN 10088-3 1.4301
	Stainless Steel 316	EN 10088-3 1.4401
Bonnet	Stainless Steel 304	EN 10088-3 1.4301
	Stainless Steel 316	EN 10088-3 1.4401
Gasket	Stainless Steel 316+Graphite	
Nut	Stainless Steel	
Handwheel	Malleable Iron	
Packing	Graphite	

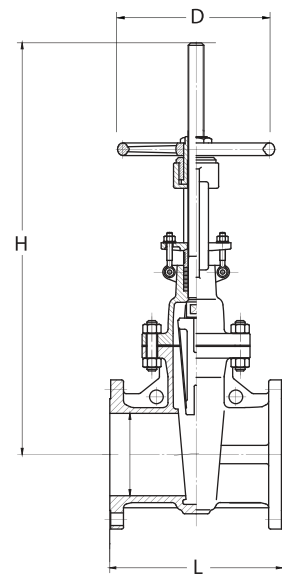

## DIMENSIONS

DN (mm)	15	20	25	32	40	50	65	80	100	125	150	200
DN (inch)	½	¾	1	1¼	1½	2	2½	3	4	5	6	8
L	130	150	160	180	200	250	265	280	300	325	350	400
H	185	210	230	302	330	360	435	515	545	695	780	935
D	120	140	160	180	200	240	240	280	300	320	360	400

## FEATURES & SPECIFICATIONS

- Rising stem, Outside Screw & Yoke (OS&Y)
- Bolted bonnet
- S-pattern body construction design
- Face to face dimension to DIN 3356
- Flange drilled to EN 1092-2 PN16 / ANSI Class 150 (Specify on order)
- Applicable for Building Services, Air-Conditioning, Fire Protection, Cold Water Plumbing, Hot Water System, Water Supply Works, Water Treatment Plant, General Industries.

## PRESSURE & TEMPERATURE RATINGS

Working Pressure	16bar
Shell Test Pressure (x1.5)	24bar
Seat Test Pressure (x1.1)	17.6bar
Working Temperature	-25°C ... 150°C
Suitable Media	Water, Oil & Gas



## MATERIAL SPECIFICATIONS

Part	Material	Specification
Body	Stainless Steel 304	EN 10088-3 1.4301
	Stainless Steel 316	EN 10088-3 1.4401
Disc	Stainless Steel 304	EN 10088-3 1.4301
	Stainless Steel 316	EN 10088-3 1.4401
Stem	Stainless Steel 304	EN 10088-3 1.4301
	Stainless Steel 316	EN 10088-3 1.4401
Gland	Stainless Steel 304	EN 10088-3 1.4301
	Stainless Steel 316	EN 10088-3 1.4401
Bolt	Stainless Steel 304	EN 10088-3 1.4301
	Stainless Steel 316	EN 10088-3 1.4401
Gasket	Stainless Steel 304	EN 10088-3 1.4301
	Stainless Steel 316	EN 10088-3 1.4401
Packing	PTFE	
Handwheel	Ductile Iron	

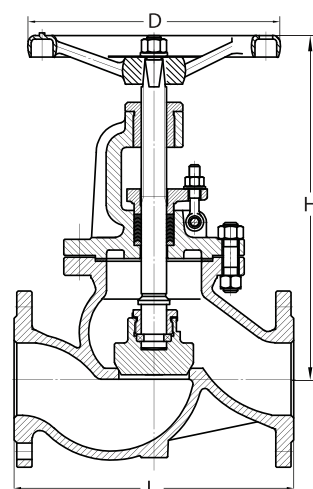

## DIMENSIONS

		(mm)											
DN	(mm)	15	20	25	32	40	50	65	80	100	125	150	200
	(inch)	½	¾	1	1¼	1½	2	2½	3	4	5	6	8
L		130	150	160	190	200	230	290	310	350	400	480	600
H		186	186	212	235	246	270	330	350	420	484	547	669
D		140	140	140	160	160	200	200	250	250	300	350	350

# STAINLESS STEEL 2-PIECE BODY BALL VALVE

SS304 PN16 F43D16-50  
SS316 PN16 F43D16-51

## FEATURES & SPECIFICATIONS

- 2 piece body full port design
- Design conforms to DIN2543 / DIN2544 / DIN2545
- Face to face dimension to DIN 3202
- Flange drilled to EN 1092-2 PN16 / ANSI Class 150 (Specify on order)
- Applicable for Building Services, Air-Conditioning, Fire-Protection, Cold Water Plumbing, Hot Water System, General Industries



## PRESSURE & TEMPERATURE RATINGS

Working Pressure	16bar
Shell Test Pressure (x1.5)	24bar
Seat Test Pressure (x1.1)	17.6bar
Working Temperature	-25°C ... 180°C
Suitable Media	Water, Oil & Gas

## MATERIAL SPECIFICATIONS

Part	Material	Specification
Body	Stainless Steel 304	EN 10088-3 1.4301
	Stainless Steel 316	EN 10088-3 1.4401
Cover	Stainless Steel 304	EN 10088-3 1.4301
	Stainless Steel 316	EN 10088-3 1.4401
Ball	Stainless Steel 304	EN 10088-3 1.4301
	Stainless Steel 316	EN 10088-3 1.4401
Seat	PTFE	
Shaft	Stainless Steel 304	EN 10088-3 1.4301
	Stainless Steel 316	EN 10088-3 1.4401
Seal	PTFE	
Nut	Stainless Steel 304	EN 10088-3 1.4301
	Stainless Steel 316	EN 10088-3 1.4401
Handle	Stainless Steel 304	EN 10088-3 1.4301

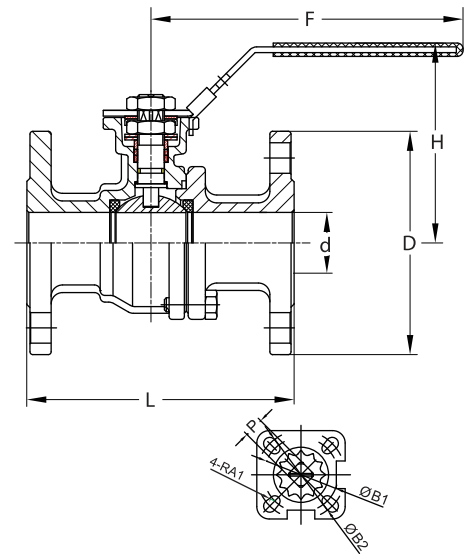

## DIMENSIONS

DN (mm) (inch)	15	20	25	32	40	50	65	80	100	125	150	200	(mm)
L	115	120	125	130	140	150	170	180	190	325	350	400	
H	80	85	95	108	114	124	148	158	191	260	278	340	
D	95	105	115	140	150	165	185	200	220	250	285	340	
d	15	20	25	32	38	50	65	76	94	125	150	200	
F	140	140	160	160	185	185	230	230	230	600	600	800	
P	9	9	11	11	14	14	17	17	17	22	22	27	
ØB1/ØB2	F03/F04	F03/F04	F04/F05	F04/F05	F05/F07	F05/F07	F07/F10	F07/F10	F07/F10	F10/F12	F10/F12	F12/F14	
Torque(N.m)	5	8	10	14	18	25	48	75	110	200	300	400	

## FEATURES & SPECIFICATIONS

- 3 piece body full port design
- Design conforms to API 598 / DIN 3202-F1
- Face to face dimension to DIN 3202-F1
- Flange drilled to EN 1092-2 PN16 / ANSI Class 150 (Specify on order)
- Applicable for Building Services, Air-Conditioning, Fire-Protection, Cold Water Plumbing, Hot Water System, General Industries



## PRESSURE & TEMPERATURE RATINGS

Working Pressure	16bar
Shell Test Pressure (x1.5)	24bar
Seat Test Pressure (x1.1)	17.6bar
Working Temperature	-25°C ... 180°C
Suitable Media	Water, Oil & Gas

## MATERIAL SPECIFICATIONS

Part	Material	Specification
Body	Stainless Steel 304	EN 10088-3 1.4301
	Stainless Steel 316	EN 10088-3 1.4401
Stem	Stainless Steel 304	EN 10088-3 1.4301
	Stainless Steel 316	EN 10088-3 1.4401
Cap	Stainless Steel 304	EN 10088-3 1.4301
	Stainless Steel 316	EN 10088-3 1.4401
Gasket	PTFE	
Ball	Stainless Steel 304	EN 10088-3 1.4301
	Stainless Steel 316	EN 10088-3 1.4401
Seat	RPTFE	
Bolt	Stainless Steel 304	EN 10088-3 1.4301
Washer	Stainless Steel 304	EN 10088-3 1.4301
Nut	Stainless Steel 304	EN 10088-3 1.4301
Stem Packing	PTFE	
Handle	Stainless Steel 304	EN 10088-3 1.4301

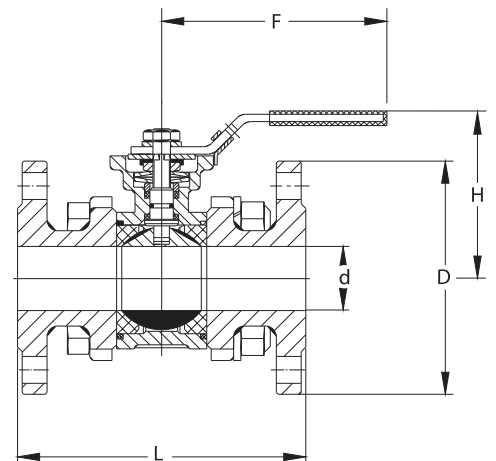

## DIMENSIONS

DN	(mm)	15	20	25	32	40	50	65	80	100	(mm)
	(inch)	½	¾	1	1¼	1½	2	2½	3	4	
L		130	150	160	180	200	230	290	310	350	
H		84	87	93	99	114	122	150	161	180	
D		95	105	115	140	150	165	185	200	235	
Ød		15	20	25	32	40	50	65	80	100	
F		148	148	170	170	212	212	254	254	285	
Torque(N.m)		5	8	10	14	18	25	48	75	110	

# STAINLESS STEEL WAFER DOUBLE DOOR CHECK VALVE

SS304 PN16 / PN25 F51DD16-50 / F51DD25-50  
 SS316 PN16 / PN25 F51DD16-51 / F51DD25-51



## FEATURES & SPECIFICATIONS

- Spring loaded double door
- Rubber seat for non-slam effect
- Comply with API 594
- Wafer connection to BS 4504 PN16 / EN 1092-2 PN16 / BS 4504 PN25 / EN 1092-2 PN25 / ANSI Class 150 (Specify on order)
- Applicable for Building Services, Air-Conditioning, Fire Protection, Cold Water Plumbing, Hot Water System, Sewerage & Water Treatment, General Industries.



## PRESSURE & TEMPERATURE RATINGS

Working Pressure	16bar	25bar
Shell Test Pressure (x1.5)	24bar	37.5bar
Seat Test Pressure (x1.1)	17.6bar	27.5bar
Working Temperature	-20°C ... 120°C	
Suitable Media	Water, Oil & Gas	

## MATERIAL SPECIFICATIONS

Part	Material	Specification
Body	Stainless Steel 304	BS970 304C15
	Stainless Steel 316	BS970 316C16
Disc	Stainless Steel 304	BS970 304C15
	Stainless Steel 316	BS970 316C16
Stem	Stainless Steel 304	BS970 304C15
	Stainless Steel 316	BS970 316C16
Washer	Stainless Steel 304	BS970 304C15
Gasket	Polytef	
Spring	Stainless Steel 304	BS970 304S15
Plug	Stainless Steel 304	BS970 304S15
Nozzle Stub	Stainless Steel 304	BS970 304S15

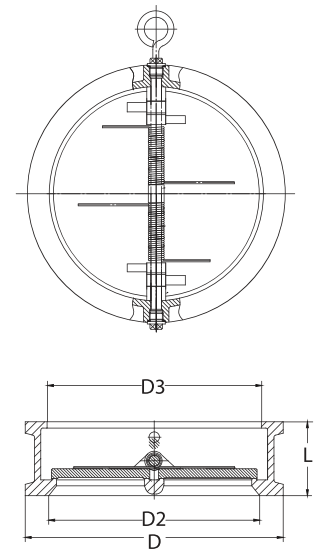

## DIMENSIONS

DN (mm)		50	65	80	100	125	150	200	250	300	350	400	450	500	600
DN (inch)		2	2½	3	4	5	6	8	10	12	14	16	18	20	24
L		60	67	73	73	86	98	127	146	181	184	191	203	219	222
D	PN16	108	128	142	162	192	218	273	329	384	444	496	556	618	695
	PN25	108	128	142	168	194	224	184	341	401	458	515	565	622	732
D2		51	65	80	102	127	152	203	254	305	350	400	450	500	600
D3		56	73	88	108	132	160	210	266	310	355	405	455	505	605

## FEATURES & SPECIFICATIONS

- Bolted bonnet
- Durable fusion bonded epoxy coated
- Flange drilled to BS 4504 PN16 / EN 1092-2 PN16 / ANSI Class 150 (Specify on order)
- Applicable for Building Services, Air-Conditioning, Fire Protection, Cold Water Plumbing, Hot Water System, General Industries.



## PRESSURE & TEMPERATURE RATINGS

Working Pressure	16bar
Shell Test Pressure (x1.5)	24bar
Seat Test Pressure (x1.1)	17.6bar
Working Temperature	-20°C ... 120°C
Suitable Media	Water, Oil & Gas

## MATERIAL SPECIFICATIONS

Part	Material	Specification
Body	Stainless Steel 304	EN 10088-3 1.4301
	Stainless Steel 316	EN 10088-3 1.4401
Disc	Stainless Steel 304	EN 10088-3 1.4301
	Stainless Steel 316	EN 10088-3 1.4401
Cover	Stainless Steel 304	EN 10088-3 1.4301
	Stainless Steel 316	EN 10088-3 1.4401
Pin	Stainless Steel 304	EN 10088-3 1.4301
	Stainless Steel 316	EN 10088-3 1.4401
Washer	PTFE	

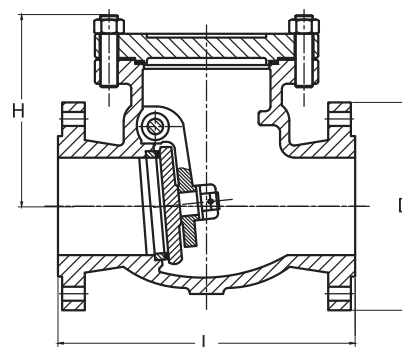

## DIMENSIONS

DN	(mm)									
	25	32	40	50	65	80	100	125	150	200
(inch)	1	1¼	1½	2	2½	3	4	5	6	8
L	160	180	200	230	290	310	350	400	480	600
H	64	68	75	97	111	120	162	179	203	236
D	115	140	150	165	185	200	220	250	285	340

# STAINLESS STEEL Y-TYPE STRAINER

SS304 PN16 F73Y16-50  
SS316 PN16 F73Y16-51



## FEATURES & SPECIFICATIONS

- Filter the particles and debris that may be carried by process fluid in the pipeline
- Bolted cover with drain plug
- Stainless steel perforated screen
- Face to face dimension to DIN 3202 F1
- Flange drilled to BS 4504 PN16 / EN 1092-2 PN16 / ANSI CLASS 150 (Specify on order)
- Applicable for Building Services, Air Conditioning, Fire Protection, Cold Water Plumbing, Hot Water System, Sewerage & Water Treatment, General Industries



## PRESSURE & TEMPERATURE RATINGS

Working Pressure	16bar
Shell Test Pressure (x1.5)	24bar
Seat Test Pressure (x1.1)	17.6bar
Working Temperature	-25°C ... 180°C
Suitable Media	Water, Oil & Gas

## MATERIAL SPECIFICATIONS

Part	Material	Specification
Body	Stainless Steel 304	EN 10088-3 1.4301
	Stainless Steel 316	EN 10088-3 1.4401
Screen	Stainless Steel 304	EN 10088-3 1.4301
	Stainless Steel 316	EN 10088-3 1.4401
Gasket	PTFE	
Gap	Stainless Steel 316	EN 10088-3 1.4401
Bonnet Bolt	Stainless Steel 304	EN 10088-3 1.4301
Stopper	Stainless Steel 316	EN 10088-3 1.4401

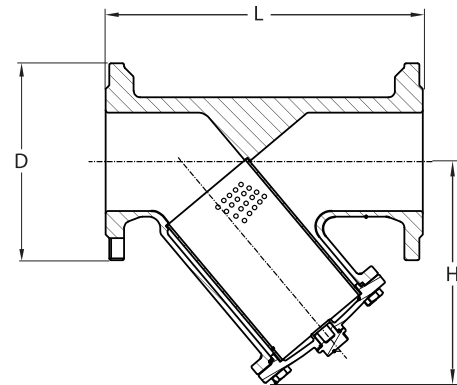

## SCREENS DATA

DN(mm)	Hole Dia. (mm)	Hole / inch <sup>2</sup>
15 ... 50	2	1
65 ... 200	3.5	2

## DIMENSIONS

DN (mm) (inch)	15 ½	20 ¾	25 1	32 1¼	40 1½	50 2	65 2½	80 3	100 4	125 5	150 6	200 8
L	130	150	160	180	200	230	290	310	350	400	480	600
H	75	90	100	115	130	150	190	225	230	280	300	400
D	95	105	115	140	150	165	185	200	220	250	285	340

## FEATURES & SPECIFICATIONS

- Threaded bonnet
- Solid wedge disc
- Non-rising stem
- Integral seat
- Full bore design
- Threaded to BS21 / ANSI B2.1 / DIN 259 / DIN 2999
- Applicable for Building Services, Air-Conditioning, Fire-Protection, Cold Water Plumbing, Hot Water System, General Industries

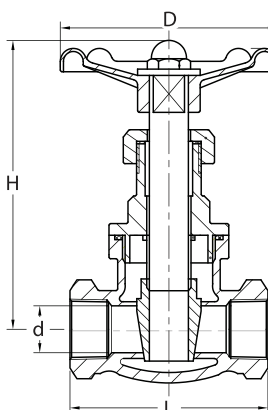

## PRESSURE & TEMPERATURE RATINGS

Working Pressure	200psi WOG Non-Shock
Shell Test Pressure	x1.5 times
Seat Test Pressure	x1.1 times
Working Temperature	-25°C ... 180°C
Suitable Media	Water, Oil & Gas

## MATERIAL SPECIFICATIONS

Part	Material	Specification
Body	Stainless Steel 304	EN 10088-3 1.4301
	Stainless Steel 316	EN 10088-3 1.4401
Disc	Stainless Steel 304	EN 10088-3 1.4301
	Stainless Steel 316	EN 10088-3 1.4401
Stem	Stainless Steel 304	EN 10088-3 1.4301
	Stainless Steel 316	EN 10088-3 1.4401
Seal	PTFE	
Gland	PTFE	
Nut	Stainless Steel 316	EN 10088-3 1.4401
Handwheel	Cast Iron	
Bonnet	Stainless Steel 316	EN 10088-3 1.4401

## DIMENSIONS

DN (mm) DN (inch)	8	10	15	20	25	32	40	50	(mm)
	¼	⅜	½	¾	1	1¼	1½	2	
L	42	42	53	57	64	73	76	88	
H	98	98	98	104	115	125	137	160	
D	65	65	65	77	77	97	97	97	
Ød	10	12	15	20	25	32	40	50	

# STAINLESS STEEL RISING STEM GLOBE VALVE

SS304 200PSI F3S200R-50  
 SS316 200PSI F3S200R-51



## FEATURES & SPECIFICATIONS

- Threaded bonnet
- Swivel disc
- Rising stem
- Full bore design
- Threaded to ANSI B2.1 / BS21 / DIN 259 / DIN 2999
- Applicable for Building Services, Air-Conditioning, Fire-Protection, Cold Water Plumbing, Hot Water System, General Industries

## PRESSURE & TEMPERATURE RATINGS

Working Pressure	200psi WOG Non-Shock
Shell Test Pressure	x1.5 times
Seat Test Pressure	x1.1 times
Working Temperature	-25°C ... 180°C
Suitable Media	Water, Oil & Gas



## MATERIAL SPECIFICATIONS

Part	Material	Specification
Body	Stainless Steel 304	EN 10088-3 1.4301
	Stainless Steel 316	EN 10088-3 1.4401
Disc	Stainless Steel 304	EN 10088-3 1.4301
	Stainless Steel 316	EN 10088-3 1.4401
Stem	Stainless Steel 304	EN 10088-3 1.4301
	Stainless Steel 316	EN 10088-3 1.4401
Cap	Stainless Steel 304	EN 10088-3 1.4301
	Stainless Steel 316	EN 10088-3 1.4401
Seal	PTFE	
Gasket	Stainless Steel 304	EN 10088-3 1.4301
Packing	PTFE	
Handwheel	Cast Iron	

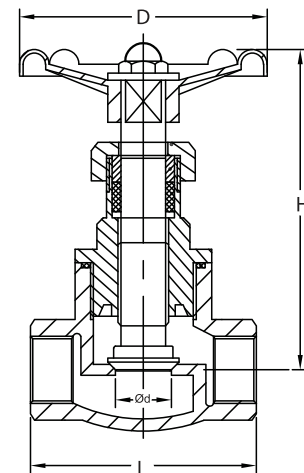

## DIMENSIONS

DN (mm)	6	10	15	20	25	32	40	50	65	80	(mm)
DN (inch)	¼	⅜	½	¾	1	1¼	1½	2	2½	3	
L	55	55	67	75	85	101	115	136	165	190	
H	79	79	79	91	106	125	136	146	177	197	
D	65	65	65	77	77	97	97	97	126	126	

## FEATURES & SPECIFICATIONS

- One-piece body
- 90° quarter turn
- Bi-direction zero-leakage
- Reduced bore design
- Blow-out proof stem
- Locking device available as option
- Design conforms to ASME B16.34
- Applicable for Building Services, Air-Conditioning, Fire-Protection, Cold Water Plumbing, Hot Water System, General Industries.



## PRESSURE & TEMPERATURE RATINGS

Working Pressure	1000psi
Shell Testing Pressure	x1.5 times
Seat Testing Pressure	x1.1 times
Working Temperature	-25°C ... 180°C
Suitable Media	Water, Oil & Gas

## MATERIAL SPECIFICATIONS

Part	Material	Specification
Body	Stainless Steel 304	EN 10088-3 1.4301
	Stainless Steel 316	EN 10088-3 1.4401
Cap	Stainless Steel 304	EN 10088-3 1.4301
	Stainless Steel 316	EN 10088-3 1.4401
Ball	Stainless Steel 304	EN 10088-3 1.4301
	Stainless Steel 316	EN 10088-3 1.4401
Seat	PTFE	
Thrust Washer	PTFE	
Packing	PTFE	
Nut	Stainless Steel 304	EN 10088-3 1.4301
Handle	Stainless Steel 304	EN 10088-3 1.4301

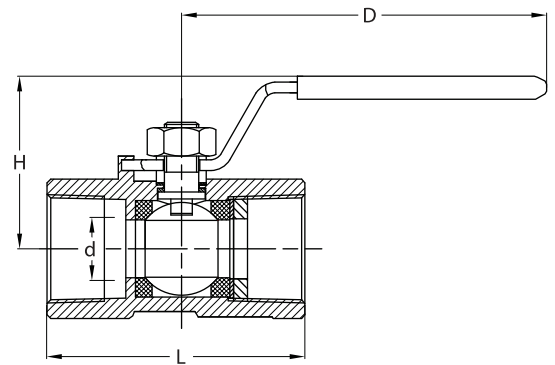

## DIMENSIONS

DN	(mm)	8	10	15	20	25	32	40	50	(mm)
	(inch)	¼	⅜	½	¾	1	1¼	1½	2	
L		40	45	56	59	71	76	84	99	
H		32	33	42	45	48	58	67	74	
D		68	68	95	95	95	106	128	130	
d		5	7	9	12.5	15	20	25	32	

## PRODUCT IDENTIFICATION CODE

CODE	F4	S	64	O	-50
	<b>F4</b> Ball Valve	<b>S</b> Stainless Steel	<b>64</b> PN64	<b>O</b> One piece body	<b>50</b> Stainless Steel 304
				<b>D</b> Two piece body	<b>51</b> Stainless Steel 316
				<b>T</b> Three piece body	

# STAINLESS STEEL 2-PIECE BODY BALL VALVE

SS304 F4S64D-50  
SS316 F4S64D-51



## FEATURES & SPECIFICATIONS

- Two-piece body
- 90° quarter turn
- Bi-direction zero-leakage
- Full bore design
- Threaded body cap
- Threaded to EN 10226-1 (ISO 7)
- Blow-out proof stem
- Locking device available as option
- Design conforms to ASME B16.34
- Applicable for Building Services, Air-Conditioning, Fire-Protection, Cold Water Plumbing, Hot Water System, General Industries.



## PRESSURE & TEMPERATURE RATINGS

Working Pressure	1000psi
Shell Testing Pressure	x1.5 times
Seat Testing Pressure	x1.1 times
Working Temperature	-25°C ... 180°C
Suitable Media	Water, Oil & Gas

## MATERIAL SPECIFICATIONS

Part	Material	Specification
Body	Stainless Steel 304	EN 10088-3 1.4301
	Stainless Steel 316	EN 10088-3 1.4401
Cap	Stainless Steel 304	EN 10088-3 1.4301
	Stainless Steel 316	EN 10088-3 1.4401
Ball	Stainless Steel 304	EN 10088-3 1.4301
	Stainless Steel 316	EN 10088-3 1.4401
Seat	PTFE	
Thrust Washer	PTFE	
Packing	PTFE	
Nut	Stainless Steel 304	EN 10088-3 1.4301
Handle	Stainless Steel 304	EN 10088-3 1.4301

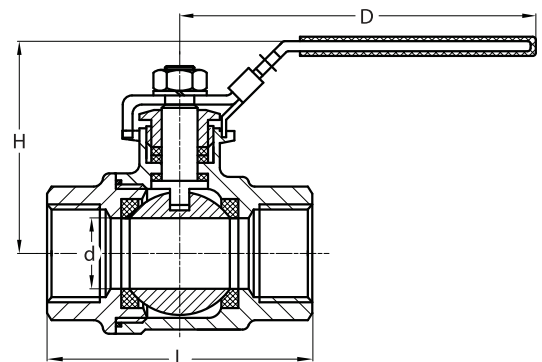

## DIMENSIONS

DN	(mm)	8	10	15	20	25	32	40	50	65	80	100	(mm)
	(inch)	¼	⅜	½	¾	1	1¼	1½	2	2½	3	4	
L		50	50	53	65	73	85	94	112	147	172	220	
H		49	49	51	58	73	79	85	95	126	138	158	
D		106	106	104	116	148	148	182	182	252	252	283	
d		11	12.5	15	20	25	32	38	50	65	76	94	
Torque(N.m)		4	4	5	8	10	14	25	40	48	80	103	

## PRODUCT IDENTIFICATION CODE

CODE	F4	S	64	D	-50
	F4	S	64	O	
	Ball Valve	Stainless Steel	PN64	One piece body	Stainless Steel 304
				D	
				Two piece body	Stainless Steel 316
				T	
				Three piece body	

## FEATURES & SPECIFICATIONS

- Three-piece body
- 90° quarter turn
- Bi-direction zero-leakage
- Full bore design
- Threaded body cap
- Threaded to EN 10226-1 (ISO 7)
- Blow-out proof stem
- Locking device available as option
- Design conforms to ASME B16.34
- Applicable for Building Services, Air-Conditioning, Fire-Protection, Cold Water Plumbing, Hot Water System, General Industries.



## PRESSURE & TEMPERATURE RATINGS

Working Pressure	1000psi
Shell Testing Pressure	x1.5 times
Seat Testing Pressure	x1.1 times
Working Temperature	-25°C ... 180°C
Suitable Media	Water, Oil & Gas

## MATERIAL SPECIFICATIONS

Part	Material	Specification
Body	Stainless Steel 304	EN 10088-3 1.4301
	Stainless Steel 316	EN 10088-3 1.4401
Bonnet	Stainless Steel 304	EN 10088-3 1.4301
	Stainless Steel 316	EN 10088-3 1.4401
Ball	Stainless Steel 304	EN 10088-3 1.4301
	Stainless Steel 316	EN 10088-3 1.4401
Seat	PTFE	
Packing	PTFE	
Seal	PTFE	
Nut	Stainless Steel 304	EN 10088-3 1.4301
	Stainless Steel 316	EN 10088-3 1.4401
Handle	Stainless Steel 304	EN 10088-3 1.4301

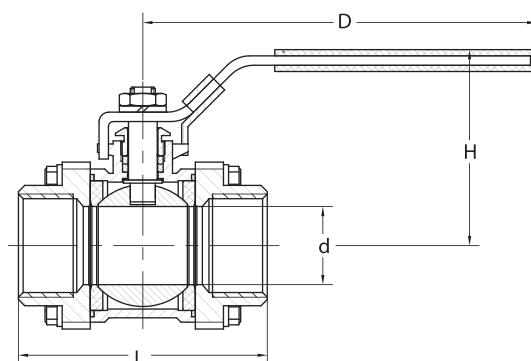

## DIMENSIONS

DN	(mm)	15	20	25	32	40	50	65	80	100	(mm)
	(inch)	½	¾	1	1¼	1½	2	2½	3	4	
L		89	102	122	130	140	158	173	201	283	
H		50	59	61	79	83	94	135	144	149	
D		103	127	127	154	154	195	244	244	285	
d		15	20	25	32	38	50	65	76	94	

## PRODUCT IDENTIFICATION CODE

CODE	F4	S	64	T	-50
	<b>F4</b> Ball Valve	<b>S</b> Stainless Steel	<b>64</b> PN64	<b>O</b> One piece body	<b>50</b> Stainless Steel 304
				<b>D</b> Two piece body	<b>51</b> Stainless Steel 316
				<b>T</b> Three piece body	

# STAINLESS STEEL 3-PIECE BODY BALL VALVE BUTT WELD

SS304 F4S64TB-50  
SS316 F4S64TB-51



## FEATURES & SPECIFICATIONS

- 3 piece body full port design
- Butt weld to ASME B16.25 / DIN 3239
- Blow-out proof stem
- Locking device available as option
- Applicable for Building Services, Air-Conditioning, Fire-Protection, Cold Water Plumbing, Hot Water System, General Industries



## PRESSURE & TEMPERATURE RATINGS

Working Pressure	1000psi
Shell Test Pressure	x1.5 times
Seat Test Pressure	x1.1 times
Working Temperature	-25°C ... 180°C
Suitable Media	Water, Oil & Gas

## MATERIAL SPECIFICATIONS

Part	Material	Specification
Body	Stainless Steel 304	EN 10088-3 1.4301
	Stainless Steel 316	EN 10088-3 1.4401
Cover	Stainless Steel 304	EN 10088-3 1.4301
	Stainless Steel 316	EN 10088-3 1.4401
Ball	Stainless Steel 304	EN 10088-3 1.4301
	Stainless Steel 316	EN 10088-3 1.4401
Seat	PTFE	
Shaft	Stainless Steel 304	EN 10088-3 1.4301
	Stainless Steel 316	EN 10088-3 1.4401
Seal	PTFE	
Nut	Stainless Steel 304	EN 10088-3 1.4301
	Stainless Steel 316	EN 10088-3 1.4401
Handle	Stainless Steel 304	EN 10088-3 1.4301

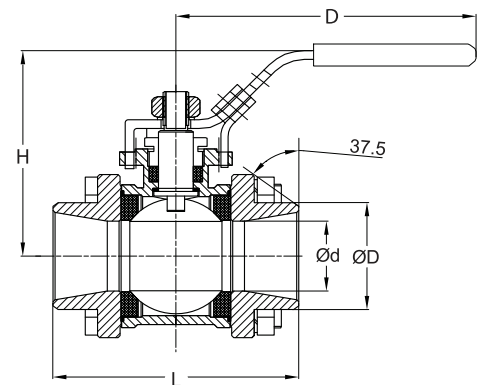

## DIMENSIONS

DN (mm) (inch)	8 ¼	10 ⅜	15 ½	20 ¾	25 1	32 1¼	40 1½	50 2	65 2½	80 3	100 4	(mm)
L	51	51	63	71	80	94	103	126	158	179	213	
H	44	45	50	59	61	79	83	94	135	144	149	
D	103	103	103	127	127	154	154	195	244	244	285	
Ød	13	13	15	20	25	32	38	50	65	76	94	
ØD	19	19	23	28	34	41	49	61	78	94	115	
Torque(N.m)	5	5	6	10	12	17	30	48	58	96	124	

## FEATURES & SPECIFICATIONS

- Swing disc
- Integral seat
- Threaded cap
- Threaded to BS21 (ISO7) / ANSI B2.1 / DIN 259 / DIN 2999
- Applicable for Building Services, Air-Conditioning, Fire-Protection, Cold Water Plumbing, Hot Water System, General Industries



## PRESSURE & TEMPERATURE RATINGS

Working Pressure	200psi WOG Non-Shock
Shell Testing Pressure	x1.5 times
Seat Testing Pressure	x1.1 times
Working Temperature	-25°C ... 180°C
Suitable Media	Water, Oil & Gas

## MATERIAL SPECIFICATIONS

Part	Material	Specification
Body	Stainless Steel 304	EN 10088-3 1.4301
	Stainless Steel 316	EN 10088-3 1.4401
Disc	Stainless Steel 304	EN 10088-3 1.4301
	Stainless Steel 316	EN 10088-3 1.4401
Pipe Plug	Stainless Steel 304	EN 10088-3 1.4301
Plug Gasket	Stainless Steel 304	EN 10088-3 1.4401
Gasket	PTFE	
Cap	Stainless Steel 304	EN 10088-3 1.4301
	Stainless Steel 316	EN 10088-3 1.4401
Seal	PTFE	

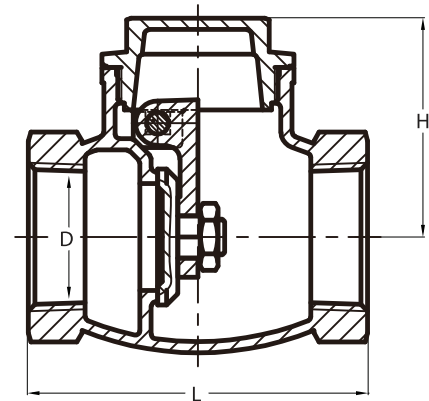

## DIMENSIONS

DN (mm) (inch)	8	10	15	20	25	32	40	50	65	80	100	(mm)
L	65	63	65	80	90	105	120	140	164	190	240	
H	42	42	42	50	58	62	72	81	94	103	136	
D	10	12	15	20	25	32	40	50	64	73	94	

# STAINLESS STEEL LIFT CHECK VALVE

SS304 F5S63L-50  
SS316 F5S63L-51

## FEATURES & SPECIFICATIONS

- Swing disc
- Integral seat
- Threaded cap
- Threaded to BS 21 (ISO7) / ANSI B2.1 / DIN 259 / DIN 2999
- Applicable for Building Services, Air-Conditioning, Fire-Protection, Cold Water Plumbing, Hot Water System, General Industries



## PRESSURE & TEMPERATURE RATINGS

Working Pressure	1000psi WOG Non-Shock
Shell Testing Pressure	x1.5 times
Seat Testing Pressure	x1.1 times
Working Temperature	-25°C ... 180°C
Suitable Media	Water, Oil & Gas

## MATERIAL SPECIFICATIONS

Part	Material	Specification
Body	Stainless Steel 304	EN 10088-3 1.4301
	Stainless Steel 316	EN 10088-3 1.4401
Cover	Stainless Steel 304	EN 10088-3 1.4301
	Stainless Steel 316	EN 10088-3 1.4401
Plug	Stainless Steel 304	EN 10088-3 1.4301
	Stainless Steel 316	EN 10088-3 1.4401
Washer	PTFE	
Spring	Stainless Steel 304	EN 10088-3 1.4301
	Stainless Steel 316	EN 10088-3 1.4401

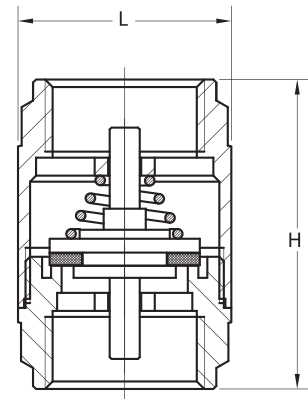

## DIMENSIONS

DN (mm)	8	10	15	20	25	32	40	50	65	80	100	(mm)
DN (inch)	1/4	3/8	1/2	3/4	1	1 1/4	1 1/2	2	2 1/2	3	4	
L	32	32	39	44	50	60	72	84	104	122	152	
H	53	53	56	63	74	81	91	97	118	138	158	

## FEATURES & SPECIFICATIONS

- Y-Pattern body
- Threaded cap
- Stainless steel mesh
- Threaded to BS 21 (ISO 7) / ANSI B2.1 / DIN 259 / DIN 2999
- Applicable for Building Services, Air-Conditioning, Fire Protection, Cold Water Plumbing, Hot Water System, General Industries.



## PRESSURE & TEMPERATURE RATINGS

Working Pressure	800psi WOG Non-Shock
Testing Pressure	x1.5 times
Working Temperature	-25°C ... 180°C
Suitable Media	Water, Oil & Gas

## MATERIAL SPECIFICATIONS

Part	Material	Specification
Body	Stainless Steel 304	EN 10088-3 1.4301
	Stainless Steel 316	EN 10088-3 1.4401
Bonnet	Stainless Steel 304	EN 10088-3 1.4301
	Stainless Steel 316	EN 10088-3 1.4401
Screen	Stainless Steel 316	EN 10088-3 1.4401
Gasket	PTFE	

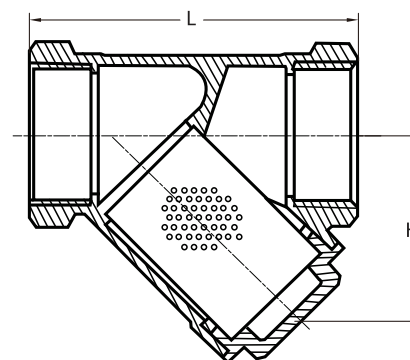

## SCREENS DATA

DN(mm)	Hole Dia. (mm)	Hole / inch <sup>2</sup>
8 ... 100	2	1

## DIMENSIONS

DN	(mm)	8	10	15	20	25	32	40	50	65	80	100
	(inch)	¼	⅜	½	¾	1	1¼	1½	2	2½	3	4
L		64	64	64	80	90	106	119	140	167	198	238
H		43	43	43	50	65	69	79	95	117	137	163

# STAINLESS STEEL EXPANSION JOINT

SS304 PN16 / PN25 F83MJ16-50 / F83MJ25-50  
 SS316 PN16 / PN25 F83MJ16-51 / F83MJ25-51

## FEATURES & SPECIFICATIONS

- Flange drilled to BS 4504 PN16 / BS EN 1092-2 PN16 / BS 4504 PN25 / BS EN 1092-2 PN25 / ANSI Class 150 (Specify on order)
- Stainless Steel 304 / Stainless Steel 316 sleeve and bellow
- Equipped with shipping rod

## APPLICATIONS

- Designed to absorb piping thermal expansion or contraction
- To accommodate vibration, reduce noise, relief stress and prevent system shock
- Suitable for applications such as pumps, compressors and other mechanical equipment
- Applicable to Building Services, Air-Conditioning, Fire-Protection, Cold Water Plumbing & Sanitary, Hot Water System, General Industries



## PRESSURE & TEMPERATURE RATINGS

Working Pressure	16bar	25bar
Test Pressure (x1.5)	24bar	37.5bar
Working Temperature	Maximum 220°C	
Suitable Media	Water, Air, Steam, Oil, Gas	

## MATERIAL SPECIFICATIONS

Part	Material
Flange	Stainless Steel 304
	Stainless Steel 316
	Carbon Steel
Bellow	Stainless Steel 304
	Stainless Steel 316
Sleeve	Stainless Steel 304
	Stainless Steel 316
Shipping Rod	Carbon Steel

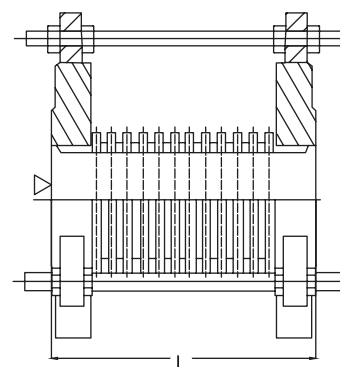

## DIMENSIONS AND MOVEMENTS

										(mm)
DN	(mm)	20	25	32	40	50	65	80	100	125
	(inch)	¾	1	1¼	1½	2	2½	3	4	5
	L	120	120	120	150	150	150	150	200	200
	Axial Movement	15	15	15	15	15	20	20	20	20

DN	(mm)	150	200	250	300	350	400	450	500	600
	(inch)	6	8	10	12	14	16	18	20	24
	L	200	250	250	250	250	300	300	300	300
	Axial Movement	20	20	20	20	20	20	20	20	20

## SPECIFICATIONS

- Flange drilled to BS 4504 PN16 / BS EN 1092-2 PN16 / BS 4504 PN25 / BS EN 1092-2 PN25 / ANSI Class 150 (Specify on order)
- Stainless Steel 304 / Stainless Steel 316 internal bellow and external braiding

## APPLICATIONS

- Designed to compensate for piping misalignment and movement
- To accommodate vibration, reduce noise, relief stress and prevent system shock
- Suitable for applications such as pumps, compressors and other mechanical equipment
- Applicable to Building Services, Air-Conditioning, Fire-Protection, Cold Water Plumbing & Sanitary, Hot Water System, General Industries

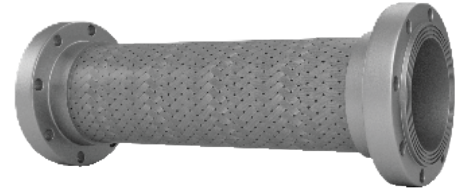

## PRESSURE & TEMPERATURE RATINGS

Working Pressure	16bar	25bar
Test Pressure (x1.5)	24bar	37.5bar
Working Temperature	Maximum 220°C	
Suitable Media	Water, Air, Steam, Oil, Gas	

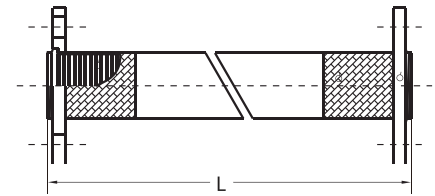

## MATERIAL SPECIFICATIONS

Part	Material
Ring	Carbon Steel
Bellow	Stainless Steel 304 Stainless Steel 316
Braiding	Stainless Steel 304 Stainless Steel 316
Flange	Carbon Steel Stainless Steel 304 Stainless Steel 316

## DIMENSIONS AND MOVEMENTS

DN (mm) (inch)	(mm)												
	20	25	32	40	50	65	80	100	125	150	200	250	300
L	300	300	300	300	300	300	300	300	300	300	300	300	300
Lateral Movement	33	33	33	33	33	32	32	26	20	18	9	7	4

Note : Special length available on request.

# STAINLESS STEEL FLEXIBLE HOSE

PN16 F85MH16  
PN25 F85MH25



## SPECIFICATIONS

- Threaded to BS EN 10226-1 (ISO 7)
- Stainless Steel 304 internal tube and external braiding

## APPLICATIONS

- Designed to compensate for piping misalignment and movement
- To accommodate vibration, reduce noise, relief stress and prevent system shock
- Suitable for applications such as pumps, compressors and other mechanical equipment
- Applicable to Building Services, Air-Conditioning, Fire-Protection, Cold Water Plumbing & Sanitary, Hot Water System, General Industries.



## PRESSURE & TEMPERATURE RATINGS

Working Pressure	16bar	25bar
Test Pressure (x1.5)	24bar	37.5bar
Working Temperature	Maximum 220°C	
Suitable Media	Water, Air, Steam, Oil, Gas	

## MATERIAL SPECIFICATIONS

Part	Material
Union Screw	Carbon Steel
	Stainless Steel 304
Union Nut	Carbon Steel
	Stainless Steel 304
Gasket	Fiber
Flexible Tube	Stainless Steel 304
Braiding	Stainless Steel 304

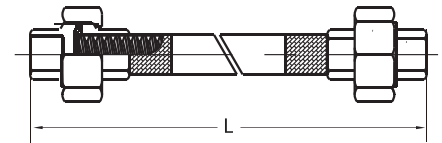

## DIMENSIONS AND MOVEMENTS

DN	(mm)	15	20	25	32	40	50	(mm)
	(inch)	½	¾	1	1¼	1½	2	
	L	300	300	300	300	300	300	
	Lateral Movement	25	25	25	20	15	20	

Note : Special length available on request.



## **FIVALCO WARRANTY STATEMENT**

Fivalco's products are designed, engineered and manufactured within its specification of intended use, under the highest quality control possible. Commitment on quality and performance is always at the top of our agenda.

Fivalco warrants that for a period of thirty six (36) months following delivery, the Fivalco products will perform in accordance with published specifications, and will be free from defects in material or workmanship provided that the products are stored and installed in accordance with recommendations in our catalogues.

Fivalco's obligation shall be to replace any product found to be defective in design, material or workmanship during the warranty period. Fivalco shall not be obligated to refund the purchase price and other liabilities on monetary compensation, nor shall it be obligated to pay for any labor or costs associated with the removal of the defective products or the reinstallation of those products. No warranty coverage will be provided for products that have been altered and / or used for a purpose other than that for which they were designed or installed contrary to Fivalco's guidelines.







# FIRE PROTECTION PRODUCTS

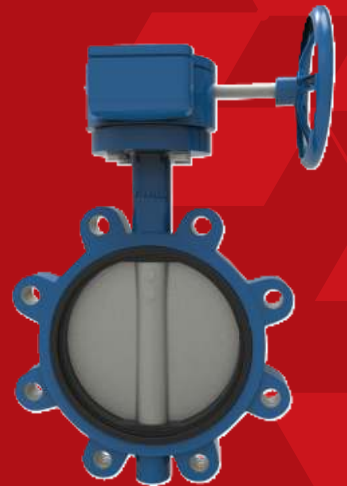

MECHANICAL  
SERVICES & HVAC





FV-SS-EN-20240630  
Fivalco® is Registered Trademark